

Stop Powdery Mildew

with S400 Professional Air Stational System

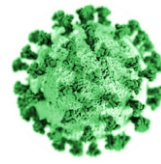

Scientific Air's S400 goes beyond filtration -- capturing airborne pathogens with a UVC dosage close and long enough for up to a **99.9995%** virus kill rate, eliminating bacteria, mold, odor, and VOC's.



Virus

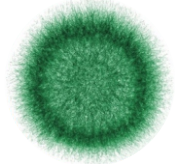

Mold

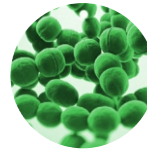

Bacteria

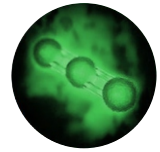

Odor VOC's

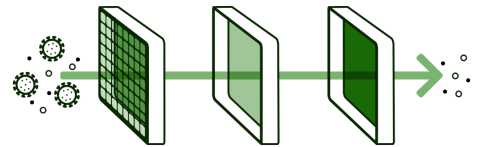

Disinfect Air -- Fast!

The S400 uses patented **UVC technology**, bio-aerosol full room size laboratory validated, to kill pathogens, reduce particulates, removes mold, odor, and VOC's in a standard 800 cubic-foot room **in minutes**.

Helps reduce airborne HAI's with up to a 99.9995% UVC pathogen killing rate.

Reduces airborne particulates by as much as 99.97%.

Quiet 24/7 UVC air scrubbing, using is entirely safe.

Powerful air management **24/7 in occupied spaces** like compounding pharmacies laboratories, food-service, and more.

Room size bio-aerosol laboratory tested

The S400 conducted two separate efficacy analysis at independent nationally recognized facilities; Microchem Laboratories and Environmental Diagnostics Laboratories. Tests were conducted in a 10'x10'x8' bio-aerosol guideline aerosolized chambers.

Test Device	Microorganism	Inoculum Concentration (CFU/ml)	Treatment Time Point	Recovery (CFU/m ³)	Percent Reduction vs. Time Zero	Log 10 Reduction vs. Time Zero
Scientific Air Management S400	MS2 Bacteriophage ATCC 15597-B1	1.00E+07	Time Zero	1.00E+06		N/A
			5 minutes	1.00E+04	99.0%	2.00
			15 minutes	1.00E+02	99.990%	4.00
			30 minutes	5.00E+00	99.9995%	5.30

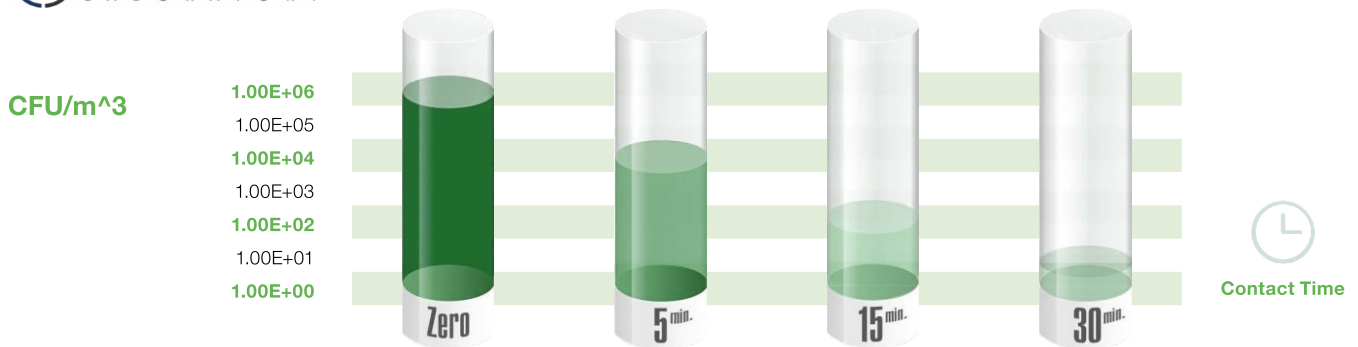

S400 Features

- High volume 400 cubic feet per minute fan operation for complete air change within 2 -5 minutes in a typical room of 800 cubic feet.
- **Powerful yet quiet brush-less high-speed motor disinfects High Volumes of air with 42 - 46 decibels at average operating speeds.**
- High capacity HEPA pre-filter cartridge captures particulates down to 0.3 microns.
- Large volume UVC induction chamber for full process of pathogen-laden air, lab tested for up to 99.9995% efficacy.
- 360-degree total air intake system creates a quiet undetectable air induction vortex.
- Patented carbon substrate for complete odor and VOC removal.
- No airflow disturbance, no temperature or humidity variations, and no negative or positive air pressure interference.
- Zero ozone production.
- 110-120 voltage standard outlet --same power requirements as a typical residential ceiling fan.
- On-Board Digital screen reporting
- HEPA Filter/Air Flow integrity metering
- UC-V Light integrity/intensity metering
- Carbon Final Filtration metering
- Pathogen and Particulate process metering
- Premium wheels for effortless mobility on all surfaces with toe touch locking wheels.
- Filter replacements available with simple economical annual self service.

Eliminates up to **99.9995%** of airborne viruses in minutes!

37" tall
22" wide
62 lbs.



S400 Specification Sheet

The S400 uses patented UVC technology, laboratory tested in bio-aerosol test chambers, to eliminate up to 99.9995% of viruses, eradicate bacteria and mold, removing up to 97% of non-viable particulates, destroying odor, and removing VOC's in a standard room in minutes!

Features

- Powerful 400 CFM fan performs complete air change disinfection within 2-5 minutes in a typical room of 800 cubic feet (10'x10'x8)
- High-capacity HEPA pre-filter reduces particulates down to 0.3 microns.
- Large-volume UVC kill chamber processing germ-laden air destroying virus, bacteria, Mold, odor, and VOC's.
- 360-degree total air circulation system is quiet, and undetectable with matching air induction and exhaust vortex.
- Zero airflow disturbance, no temperature or humidity variations, no negative or positive air pressure interference, NO by products, NO ozone.
- Lightweight 62 lbs. With aluminum balanced security base for superb stability and safety.
- 110-120 voltage standard outlet with the same power requirements as a typical residential ceiling fan.
- Green-Dot grounded electrical cord.
- On-Board Digital screen reporting:
 - a. HEPA filter/air flow integrity
 - b. Carbon final filtration integrity
 - c. UVC light intensity/integrity
 - d. Processed CFM air volume
- Premium wheel for effortless mobility on all surfaces with touch toe locking casters.
- Consumable component "snap-in snap-out" replacements with simple and economical annual self service.
- Dimensions 22"W x 37"H 62lbs.

Specification

Physical Dimensions

- 22 x 37 inches
- Weighs 62 pounds

Electrical Ratings

- Rated at 110 volts
- Rated at 1.6 Amps
- Green Dot Grounded

Decibel Level

- 62-64 decibels Certifications
- MET US/C UL 507

Construction

- High grade steel
- Antimicrobial powder coating
- Aluminum wheel base

Air Circulation

- 400 CFM Motor Fan Speed
- Will not affect positive/negative pressure
- Air intake matches air exhaust
- 360 degree vortex air flow over a large surface area.
- Will not affect room air exchanges or room air flow.

Disinfection Process

- HEPA (0.3 um) pre-filter
- UV-C 253.7nm (254 nm) 36W non-ozone light array
- Treated carbon-coir substrate final filter granulated moisture resistant

Cleaning

- Wipe down entire machine with
- Antibiotic cleaner

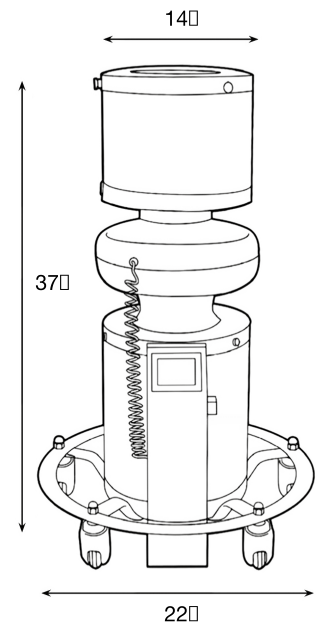

120VAC 1.2A 60Hz

EPA Est.
92896-FL-1



airocleanTM420
by SteriLumen

info@airoclean420.com

844.247.3913

www.airoclean420.com

